



6/1 Howie Avenue Cronulla NSW

1 1 1

Boasting an effortless stroll to Cronulla's vibrant beaches and amenities, this north facing top floor apartment is situated in a small complex of only eight and is perfect for those looking for a quiet and convenient lifestyle.

View : <https://www.gibsonpartners.com/lease/nsw/sutherland/cronulla/residential/apartment/5854592>

Featuring immaculately presented modern interiors, this light filled property offers the following;

- Top floor position with sunny northerly aspect
- Spacious lounge & dining
- Open plan kitchen with plenty of bench space & cupboard storage
- Good sized bedroom with BIR, ensuite bathroom with bath
- Small block of only 8 apartments, registered single car space



Amber Dare
02 9523 1333

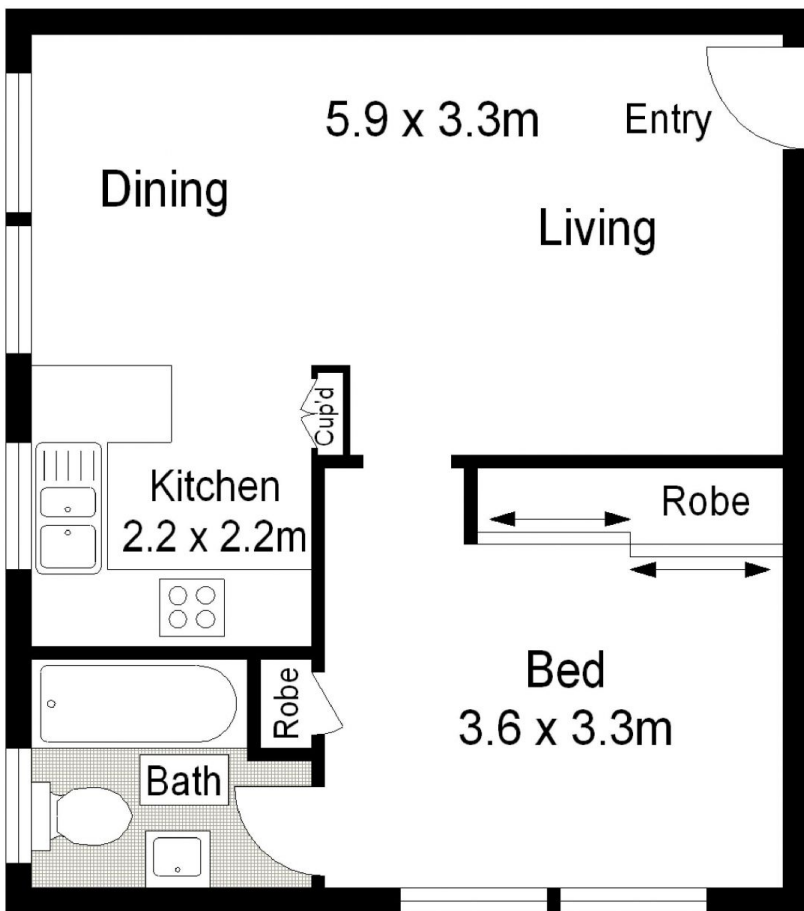

FIRST FLOOR

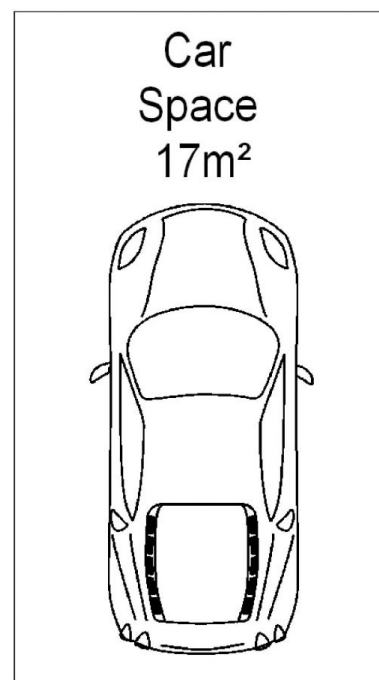

GROUND FLOOR



SCALE IN METERS.

Gibson Partners Real Estate Pty Ltd

Scale in metres. Indicative only. Dimensions are approximate. All information contained herein is gathered from sources we believe to be reliable. However we cannot guarantee its accuracy and interested persons should rely on their own enquiries.



6/1 Howie Avenue, Cronulla

GIBSON